



# JCB TELETRUK | TLT 25/TLT 25HL/TLT 30/TLT 35



ENGINE FUEL TYPE:

DIESEL OR LPG

LIFT CAPACITY:

UP TO 3.5 TONNES

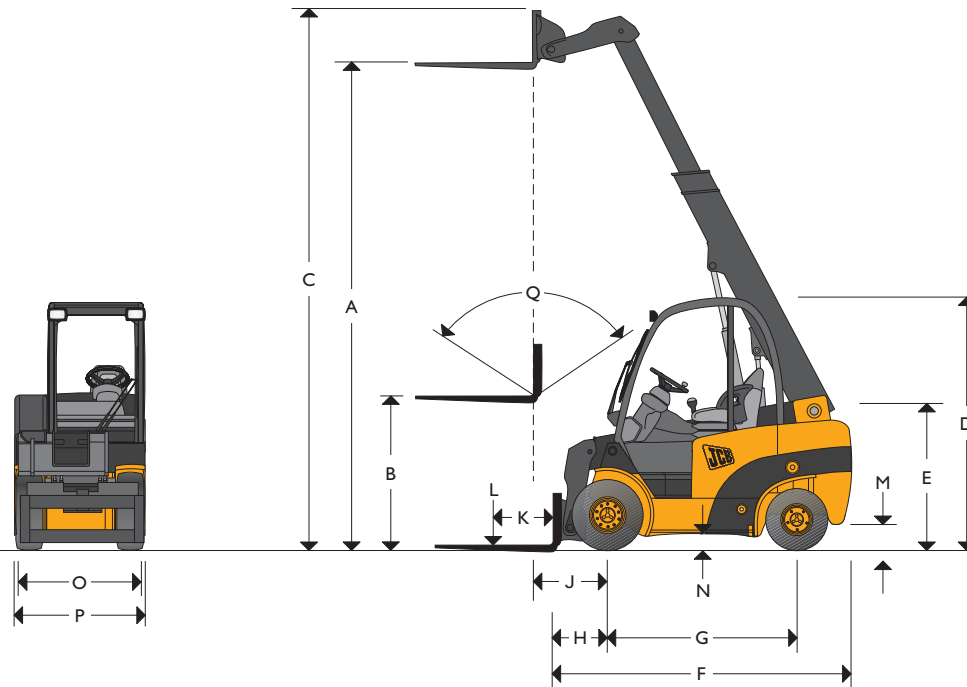

## STATIC DIMENSIONS

Model		TLT25/25HL	TLT30	TLT35*
A	Lift height	mm 4100	4100	4400
B	Free lift (standard)	mm 1424	1410	1210
C	Height boom extended	mm 4580	4625	4975
D	Height of overhead guard (std/low)	mm 2190/2090	2205/2105	2205/2105
E	Height of operator's seat (std/low)	mm 1086/1066	1091/1071	1200/1180
F	Length to fork face	mm 2625	2750	3000
G	Wheelbase	mm 1700	1700	1950
H	Distance from c/l of front axle to fork face	mm 500	515	595

Model		TLT25/25HL	TLT30	TLT35*
J	Distance from c/l of front axle to fork face	mm 700	715	795
K	Load centre	mm 500	500	500
L	Lift capacities (with sideshift)	kg 2500	3000	3500
M	Ground clearance (lowest point)	mm 115	130	125
N	Ground clearance wheelbase centre	mm 140	155	155
O	Fork carriage width	mm 1100	1200	1200
P	Maximum width of machine	mm 1175	1280	1280
Q	Carriage tilt total* F/B variable through lift arc	degrees 111*	111*	111



# JCB TELETRUK | TLT 25/TLT 25HL/TLT 30/TLT 35



## GENERAL SPECIFICATION

Model	TLT25/25HL	TLT30	TLT35*
Engine type	Diesel/LPG	Diesel/LPG	Diesel
Engine manufacture	D-JCB/G-G.M.	D-JCB/G-G.M.	D-JCB
Engine model	D-404 2.2/G-3.0 L4	D-404 2.2/G-3.0 L4	D-404 2.2
Engine output (gross power)	kW D-37/G-43	D-37/G-43	44.6
Rated rpm	D-2600/G-2600	D-2600/G-2600	2800
Number of cylinders	D-4/G-4	D-4/G-4	4
Cubic capacity	cm <sup>3</sup> D-2200/G-2966	D-2200/G-2966	2200
Working pressure for attachments	bar 170	170	170
Oil flow for attachments	l/min 70	70	70
Maximum reach ground level (500mm load centre)	mm 2230	2230	2280
Maximum reach boom horizontal (500mm load centre)	mm 2390	2390	2430
Turning radius	mm 2440	2490	2885
Aisle width 90° stacking 800 x 1200/1000 x 1200	mm 3940/4140	4005/4205	4480/4680
Weight unladen	kg D-4220/G-4280 D-4340/G-4400	D-4900/G-4960	5100
Travel speed (standard)	km/h 20	20	20
Gradeability (laden/unladen)	% 25/21	25/21	25/21
Transmission	TCR/I.T.	TCR/I.T.	TCR
Park brake type	Hand	Hand	Hand
Shovel rated capacity	m <sup>3</sup> 0.6	0.6	0.6
Shovel struck capacity	m <sup>3</sup> 0.5	0.5	0.5
Shovel dump height (30°)	mm 2400	2400	2680
Shovel rollback angle at ground	degrees 37	37	33
Shovel width	mm 1385	1385	1385
Tyres PPS (semi-solid), L (pneumatic)	PPS/L	PPS/L	PPS/L
Tyre size front (standard)	7.00 x 12	27 x 10 x 12	27 x 10 x 12
Tyre size rear (standard)	6.00 x 9	6.50 x 10	23 x 9 x 10

\*Provisional data as at April 2004.

## STANDARD FEATURES

- Versatile telescopic two-piece boom.
- Superb forward visibility.
- Information display centre (I.D.C) complete with warning lights, hourmeter.
- JCB 'TCR' torque converter response transmission.
- 'JCB Intelligent' hydrostatic transmission.
- Comfortable operator's enclosure (structure fully meets international safety standards for (ROPS) Roll-Over Protection and (FOPS) Falling Object Protection).
- Seat belt and hip restraint on fully adjustable seat.
- Load moment indicator.
- Self levelling forks.
- Hose-burst-check valves on tilt, lift, and extension ram circuits.
- Front screen guard.
- Operator's daily checks completed via single easy-access panel, and excellent service access to major components.
- Battery isolator.
- Security etched glazing.
- Working lights front and rear.
- 111 Degree carriage tilt.
- Bucket mode switch.

## OPTIONS

Over 100 build options, including:

- Choice of pneumatic, foam filled or PPS tyres.
- Lightweight re-handling shovel.
- Bagezee 'trapdoor' shovel for loading/filling big bags in single operation.
- Quick disconnect system for easy changing between attachments.
- Sideshift carriage and various forks.
- Range of load guards, attachments, exhaust purification systems, etc.
- Various operator environments: safety mesh to operator's right, glazing to front/rear/top. Full cab with door and heater or air conditioning.
- Low-height cab (for containers check height and floor loadings).
- Vinyl or fabric seat in high/standard/low versions.
- Roadlights.
- Flow divider.



# JCB TELETRUK | TLT 25/TLT 25HL/TLT 30/TLT 35



## LIFT CAPACITIES

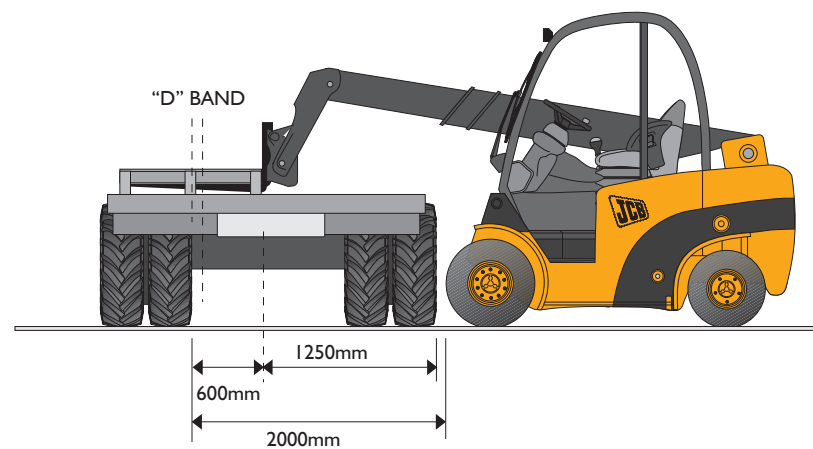
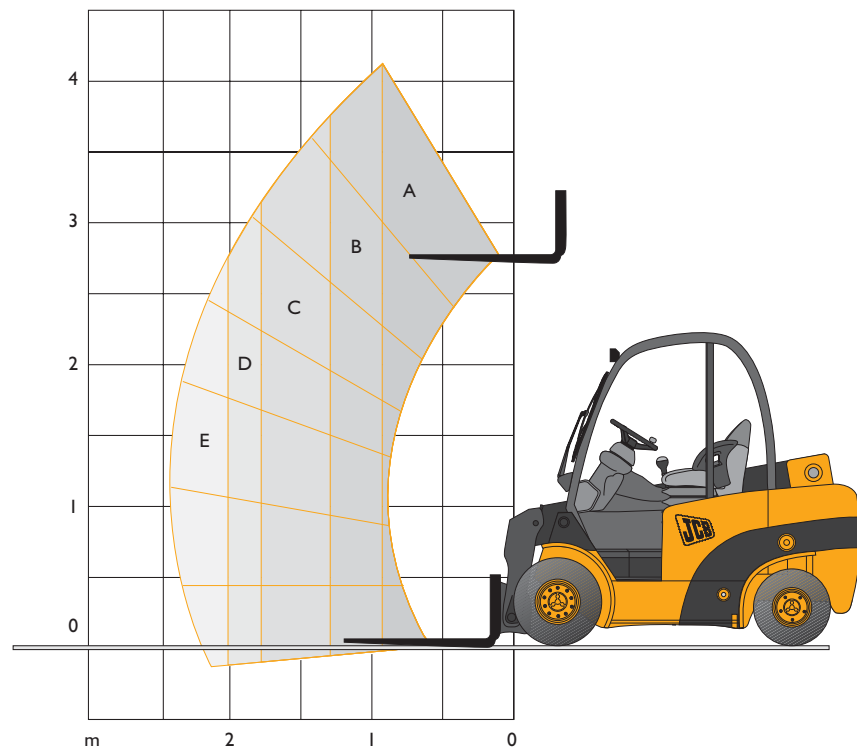

Capacity bands	TLT 25	TLT 25HL	TLT 30	TLT 35
A	2500kg	2500kg	3000kg	3500kg
B	2000kg	2175kg	2500kg	3000kg
C	1500kg	1650kg	2000kg	2500kg
D	1275kg	1400kg	1750kg	2100kg
E	1000kg	1075kg	1500kg	1700kg



JCB TELETRUK | TLT 25/TLT 25HL/TLT 30/TLT 35



## A GLOBAL COMMITMENT TO QUALITY

JCB's total commitment to its products and customers has helped it grow from a one-man business into Britain's largest privately owned manufacturer of backhoe loaders, crawler excavators, wheeled excavators, telescopic handlers, wheeled loaders, dump trucks, rough terrain fork lifts, industrial fork lifts, mini/midi excavators, skid steer loaders and tractors.

By making constant and massive investments in the latest production technology, the JCB factories have become some of the most advanced in Europe.

By leading the field in innovative research and design, extensive testing and stringent quality control, JCB machines have become renowned all over the world for performance, value and reliability.

And with a global sales and service network of over 400 distributors and agents, the company exports over 70% of its production to all five continents.

Through setting the standards by which others are judged, JCB has become one of Britain's most impressive success stories.

